

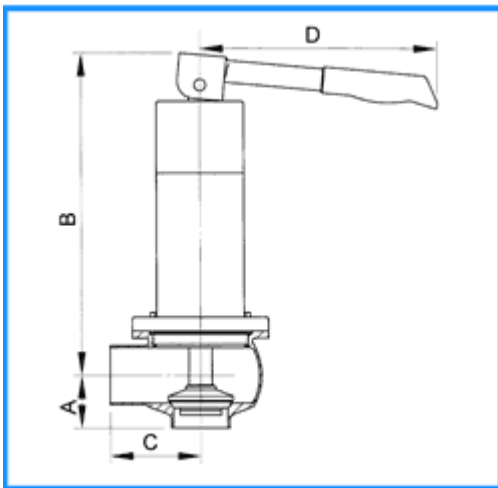

a  stainless technologies company



Diamond Series 3 Pressure Relief Valves



Designed to meet the changing needs of the process industry, the new Series 3 Pressure Relief valve uses elements of the DPL single and double seat valves to produce a full bore, self draining device ranging in size from 1-4". Available in manual and actuated format, the Series 3 valves have a tamper-proof pressure setting mechanism which can be adjusted in-line. The valve can be disassembled for servicing without affecting the factory pressure setting.

- Full bore.
- Self draining to reduce the risk on contamination
- Profiled seat seal to ensure a secure seal
- 316L forged material for better corrosion resistance
- Captive spring to ensure consistent system pressure settings
- Wide range of seat materials appropriate for a wide range of applications
- Suitable for CIP for full compatibility with your process systems
- Steam sterilisable giving you complete peace of mind
- Serviceable in-line to avoid costly downtime during maintenance

Size	1"	1.5"	2"	2.5"	3"	4"
A	30.5	42	45.5	55	59	71
B	185	275	280	305	310	330

C	52	75	79	95	99	127
D	150	210	210	210	210	210

Size (ins)	Spring Ratings (psi)								
	0-30	0-35	0-40	0-60	0-65	0-80	0-90	0-100	0-150
1.0"	DP58							DP59	DP94
1.5"			DP64		DP65			DP62	DP55
2.0"		DP65		DP62				DP55	DP95
2.5"			DP66	DP67				DP66/67	DP96
3.0"	DP66			DP69			DP66/69		DP96
4.0"	DP69					DP96			

Group use according to the Pressure Equipment Directive

With regard to the Pressure Equipment Directive (PED) the Pressure Relief Valves produced by DPL are designated as manufactured to Sound Engineering Practice (not to be CE marked). The valves are for use with piping media content within Group 2 and a pressure range 0 to 10 bar g.

Accordingly DPL valves are marked with the relevant directive number and S.E.P.

Working temperatures dependent upon choice of seal material, please consult DPL if in doubt



ATEX approved version available for use in potentially explosive atmospheres.

Group 2, Category 2, Gas and dust compliant

Dairy Pipe Lines Ltd. Tipton Road, Dudley. DY1 4SQ
 Tel: +44 (0)1799 522 885
 Email: dairypipelines@dpluk.co.uk **www.dpluk.co.uk**