

Diamond Butterfly Valves

The **Diamond Butterfly Valve** is a hygienic, in-line, 1/4 turn or multi-position unit for manual and actuated service.

- Fully machined from 316L forgings for a high quality, non porous construction.
- Polished, crevice free disc which is easily cleaned.
- 'O' ring spindle is environmentally sealed.
- Spindle bearings fit into seal cross holes resulting in low torque.
- Range of seal materials available including EPDM, Silicone, Viton steam resistant and Nitrile to suit your application.

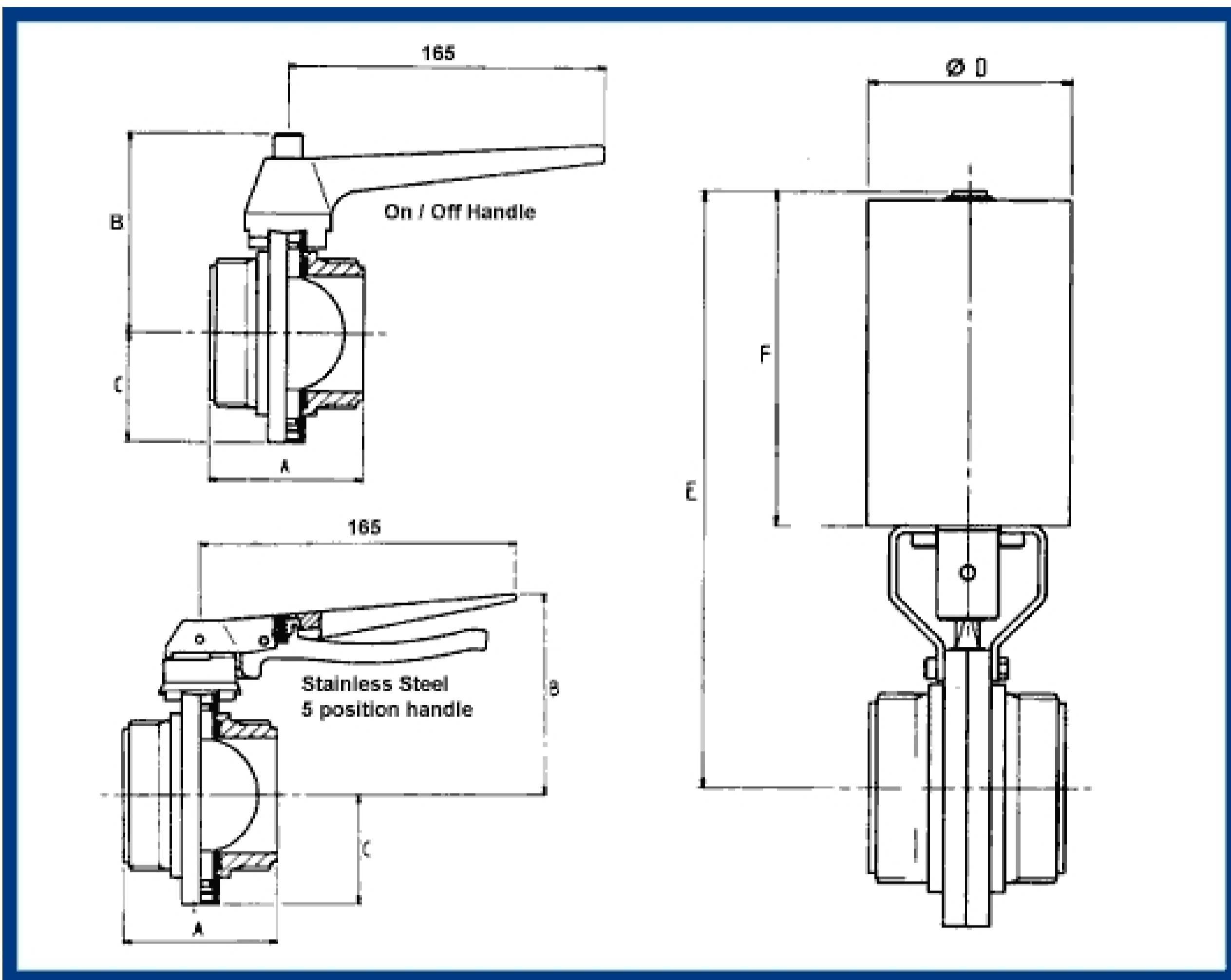



DIAMOND BUTTERFLY VALVES

Other Dimensions

SIZE	1.0"	1.5"	2.0"	2.5"	3.0"	4.0"
B mm	90	94	101	107	113	129
C mm	39.5	43.5	50.5	57	63	79
Dia. D mm	83	83	83	102	102	102
E mm	231	235	242	268	275	291
F mm	138	138	138	160	160	160

ACTUATION AND CONTROL

Butterfly valves can be supplied fitted and tested with a comprehensive range of pneumatic and electric actuators including all ancilliary equipment such as solenoids, limit switches and positioners.

ATEX-approved version available for use in potentially explosive atmospheres.

Group 2, Category 2, Gas and dust compliant